

Beaver Watershed Alliance  
P.O. Box 762  
Elkins, AR 72727  
Phone: (479) 750-8007

**REQUEST FOR PROPOSALS:** RFP 25-01, Low Impact Development Contracting Services

**DEADLINE:** Date February 28, 2025, prior to 2:00:00 PM, local time

**DELIVERY LOCATION:** 162 Doolin Drive, Elkins, AR 72727 – must schedule time to deliver by contacting below, or mail to P.O. Box 762, Elkins, AR 72727.

**PRIMARY CONTACT:** Emily Finley, [emily@beaverwatershedalliance.org](mailto:emily@beaverwatershedalliance.org)

**PROPOSAL DELIVERY CONTACT:** Emily Finley, [emily@beaverwatershedalliance.org](mailto:emily@beaverwatershedalliance.org) (479) 502-4388.

**DATE OF ISSUE AND ADVERTISEMENT:** Sunday, February 2, 2025, Sunday, February 16, 2025.

Notice is hereby given that the Beaver Watershed Alliance (BWA) is seeking Request for Proposals from qualified contracting firms related to the **Smart Growth for Source Water Protection** grant project.

The work will generally consist of contracting services for the implementation of a demonstration low impact development (LID) project located within the Beaver Lake watershed. The project goal is to reduce Nonpoint Source (NPS) sediment and nutrient loads and improve water quality through the implementation of this demonstration LID project as a water quality Best Management Practice (BMP).

The purpose of this request is to select a contractor that is best qualified to assist the BWA with the construction of the completed design prepared by Hodges Engineering, following the construction plans and specifications for the project.

Proposals shall be submitted in sealed envelopes labeled with the solicitation number, solicitation name, and the name and address of the Proposer.

All proposals shall be submitted in accordance with the Beaver Watershed Alliance specifications and documents attached hereto. Each Proposer is required to fill in every blank and shall supply all information requested. Failure to do so may be used as basis of rejection. Any proposal that violates or conflicts with state, local, or federal laws, ordinances, or policies will be rejected.

---

The undersigned hereby offers to furnish and deliver the articles or services as specified, at the terms stated herein, and in strict accordance with the specifications and general conditions of submitting, all of which are made a part of this offer. This offer is not subject to withdrawal unless upon mutual written agreement by the Proposer and the Beaver Watershed Alliance.

---

Beaver Watershed Alliance  
RFP 25-01, Low Impact Development Contracting Services  
Advertisement

---

The Beaver Watershed Alliance is requesting proposals from qualified contracting firms interested in providing LID construction services for the *Smart Growth for Source Water Protection* grant project.

To be considered, proposals shall be received at the Beaver Watershed Alliance offices, located at 162 Doolin Drive, Elkins, Arkansas by **February 28, 2025, prior to 2:00:00 PM**, local time. **No late submittals will be accepted.** Proposal delivery must be scheduled prior by contacting [emily@beaverwatershedalliance.org](mailto:emily@beaverwatershedalliance.org) or (479) 502-4388 or mail to P.O. Box 762, Elkins, AR 72727.

A pre-bid meeting will be held at the project site at 597 East Miracle Drive, Fayetteville, Arkansas 72701, on **Monday, February 10, 2025, at 4:00 PM** local time.

Forms and addendums can be downloaded from the Beaver Watershed Alliance's web site at <https://www.beaverwatershedalliance.org/alliance-seeking-proposals-for-low-impact-development-project/>. All questions regarding the process should be directed to Emily Finley at [emily@beaverwatershedalliance.org](mailto:emily@beaverwatershedalliance.org) or (479) 502-4388.

Proposals submitted shall be from contractors that are qualified to do business and licensed in accordance with all applicable laws of the state and local governments where the projects are located.

Pursuant to Arkansas Code Annotated §22-9-203, the Beaver Watershed Alliance encourages all *qualified* small, minority and women business enterprises to bid on and receive contracts for goods, services, and construction. Also, the Beaver Watershed Alliance encourages all general contractors to subcontract portions of their contract to *qualified* small, minority and women business enterprises.

The Beaver Watershed Alliance reserves the right to reject any or all proposals and to waive irregularities therein, and all Proposers shall agree that such rejection shall be without liability on the part of the Beaver Watershed Alliance for any damage or claim brought by any Proposer because of such rejections, nor shall the Proposers seek any recourse of any kind against the Beaver Watershed Alliance because of such rejections. The filing of any Proposal in response to this invitation shall constitute an agreement of the Proposer to these conditions.

BEAVER WATERSHED ALLIANCE

By: Becky Roark

Title: Executive Director

Ad date: Feb 2, Feb 16, 2025

Beaver Watershed Alliance  
RFP 25-01, Low Impact Development Contracting Services  
Table of Contents

---

<b>SECTION:</b>	<b>PAGE NUMBER</b>
Cover Page	1
Advertisement	2
SECTION A: General Terms and Conditions	4
SECTION B: Scope of Work	11
SECTION C: Firm Organizational Summary and References	12
SECTION D: Authorized Signature Submittal	15
APPENDIX A: Project Information and Documentation	18

Beaver Watershed Alliance  
RFP 25-01, Low Impact Development Contracting Services  
SECTION A: General Terms and Conditions

---

1. **SUBMISSION OF A PROPOSAL SHALL INCLUDE:**

- a. A written narrative describing the method or manner in which the Proposer proposes to satisfy requirements of this RFP in the most cost-effective manner. The term Proposer shall be in reference to a firm, team of firms or individual responding to this solicitation.
- b. A description of the Proposer's experience in providing the same or similar services as outlined in the RFP. This description should include the names of the person(s) who will provide the services, their qualifications, and the years of experience in performing this type of work. Also, include the reference information requested in this RFP.
- c. Proposal shall include three examples of similar work within the past five years and provide reference contact information for each.
- d. Proposal should be no more than twenty-five (25) pages; single sided, standard, readable, print on standard 8.5" x 11" papers. Proposers are also allowed to submit a three (3) page (maximum) executive summary. The following items will not count toward the page limitations: appendix, cover sheet, 3-page executive summary, resumes (resumes shall be no more than 1 page per person), and forms provided by the BWA for completion.
- e. All Proposers shall submit five (5) paper copies of their proposal as well as one (1) electronic copy on a properly labeled CD or other electronic media device. **The electronic copy submitted should be submitted as a SINGLE FILE in format acceptable to Adobe in a save able format.** Files contained on the CD or electronic media shall not be restricted against saving or printing. **The electronic copy shall be identical to the original papers submitted.** Electronic copies shall not be submitted via e-mail to BWA employees by the Proposer.
- f. Proposals will be reviewed following the stated deadline, as shown on the cover sheet of this document. Only the names of Proposers will be available after the deadline until a contract has been awarded by the Beaver Watershed Alliance. All interested parties understand proposal documents will not be available until after a valid contract has been executed and at that time only for the intended selection.
- g. Proposers shall submit a proposal based on documentation published by the Beaver Watershed Alliance.
- h. Proposals shall be enclosed in sealed envelopes or packages addressed to the Beaver Watershed Alliance, 162 Doolin Drive, Elkins, Arkansas 72727, or mailed to P.O. Box 762, Elkins, Arkansas 72727. The name, address of the firm and RFP number shall be on the outside of the packaging as well as on any packages enclosed in shipping containers or boxes.
- i. Proposals must follow the format of the RFP. Proposers should structure their responses to follow the sequence of the RFP.
- j. Proposers shall have experience in work of the same or similar nature and must provide references that will satisfy the Beaver Watershed Alliance. Proposer may furnish a reference list of clients for whom they have performed similar services and must provide information as requested in this document.
- k. Proposer is advised that exceptions to any of the terms contained in this RFP or the attached service agreement must be identified in its response to the RFP. Failure to do so may lead the BWA to declare any such term non-negotiable. Proposer's desire to take exception to a non-negotiable term will not disqualify it from consideration for award.
- l. Local time shall be defined as the time in Elkins, Arkansas on the due date of the deadline. Documents shall be received before the deadline time as shown.

**2. WRITTEN REQUESTS FOR INTERPRETATIONS OR CLARIFICATION:**

No oral interpretations will be made to any contractors as to the meaning of specifications or any other contract documents. All questions pertaining to the terms and conditions or scope of work of this proposal must be sent in writing via e-mail to the Beaver Watershed Alliance. Responses to questions may be handled as an addendum if the response would provide clarification to the requirements of the proposal. All such addenda shall become part of the contract documents. The BWA will not be responsible for any other explanation or interpretation of the proposed RFP made or given prior to the award of the contract.

**3. RIGHTS OF BEAVER WATERSHED ALLIANCE IN THIS PROCESS:**

In addition to all other rights of the Beaver Watershed Alliance, under state law, the BWA specifically reserves the following:

- a. The Beaver Watershed Alliance reserves the right to rank firms and negotiate with the highest-ranking firm. Negotiation with an individual Proposer does not require negotiation with others.
- b. The Beaver Watershed Alliance reserves the right to select the proposal that it believes will serve the best interest of the BWA.
- c. The Beaver Watershed Alliance reserves the right to accept or reject any or all proposals.
- d. The Beaver Watershed Alliance reserves the right to cancel the entire request.
- e. The Beaver Watershed Alliance reserves the right to remedy or waive technical or immaterial errors in the request for proposals or resulting submittal.
- f. The Beaver Watershed Alliance reserves the right to request any necessary clarifications, additional information, or proposal data without changing the terms of the proposal.
- g. The Beaver Watershed Alliance reserves the right to make selection of the Proposer to perform the services required on the basis of the original proposals without negotiation.
- h. The Beaver Watershed Alliance intends on utilizing the received proposals for applicable Low Impact Development Grant projects. Projects believed to be under \$20,000 by the BWA will be selected by the BWA in accordance with the presented selection criteria in this RFP. Projects expected to exceed \$20,000 shall be voted on by the selection committee and any related contract exceeding \$20,000 shall require formal authorization by the Beaver Watershed Alliance.

**4. EVALUATION CRITERIA:**

The evaluation criterion defines the factors that will be used by the selection committee to evaluate and score responsive, responsible and qualified proposals. Proposers shall include sufficient information to allow the selection committee to thoroughly evaluate and score proposals. Each proposal submitted shall be evaluated and ranked by a selection committee. The contract will be awarded to the most qualified Proposer, per the evaluation criteria listed in this RFP. Proposers are not guaranteed to be ranked.

**5. COSTS INCURRED BY PROPOSERS:**

All expenses involved with the preparation and submission of proposals to the BWA, or any work performed in connection therewith, shall be borne solely by the Proposer(s). No payment will be made for any responses received, or for any other effort required of, or made by, the Proposer(s) prior to contract commencement.

**6. ORAL PRESENTATION:**

An oral presentation and/or interview may be requested of any Proposer at the selection committee's discretion.

**7. CONFLICT OF INTEREST:**

- a. The Proposer represents that it presently has no interest and shall acquire no interest, either direct or indirect, which would conflict in any manner with the performance or services required hereunder.

- b. The Proposer shall promptly notify Emily Finley, BWA Urban Watershed Specialist, in writing, of all potential conflicts of interest for any prospective business association, interest, or other circumstance which may influence or appear to influence the Proposer's judgment or quality of services being provided. Such written notification shall identify the prospective business association, interest or circumstance, the nature of which the Proposer may undertake and request an opinion to the BWA as to whether the association, interest or circumstance would, in the opinion of the BWA, constitute a conflict of interest if entered into by the Proposer. The BWA agrees to communicate with the Proposer its opinion via e-mail or first-class mail within thirty days of receipt of notification.

**8. WITHDRAWAL OF PROPOSAL:**

A proposal may be withdrawn at any time.

**9. LATE PROPOSAL OR MODIFICATIONS:**

- a. Proposals and modifications received after the time set for the proposal submittal shall not be considered. Modifications in writing received prior to the deadline will be accepted. The BWA will not be responsible for misdirected proposals. Proposers should call the Beaver Watershed Alliance at (479) 750-8007 to ensure receipt of their submittal documents prior to opening time and date listed.
- b. The time set for the deadline shall be local time for Elkins, AR on the date listed. All proposals shall be received in the Beaver Watershed Alliance offices BEFORE the deadline stated at 162 Doolin Drive, Elkins, Arkansas 72727.

**10. LOCAL, STATE, AND FEDERAL COMPLIANCE REQUIREMENTS:**

- a. The laws of the State of Arkansas apply to any purchase made under this request for proposals. Proposers shall comply with all local, state, and federal directives, orders and laws as applicable to this proposal and subsequent contract(s) including but not limited to Equal Employment Opportunity (EEO), Disadvantaged Business Enterprises (DBE), and OSHA as applicable to this contract.
- b. Pursuant to Arkansas Code Annotated §22-9-203, the Beaver Watershed Alliance encourages all *qualified* small, minority and women business enterprises to bid on and receive contracts for design services. Also, the Beaver Watershed Alliance encourages all Proposers to subcontract portions of their contract to *qualified* small, minority and women business enterprises.

**11. COLLUSION:**

The Proposer, by affixing his or her signature to this proposal, agrees to the following: "Proposer certifies that his proposal is made without previous understanding, agreement, or connection with any person, firm or corporation making a proposal for the same item(s) and/or services and is in all respects fair, without outside control, collusion, fraud, or otherwise illegal action."

**12. RIGHT TO AUDIT, FOIA, AND JURISDICITON:**

- a. The Beaver Watershed Alliance reserves the privilege of auditing a vendor's records as such records relate to purchases between the BWA and said vendor.
- b. Freedom of Information Act: Contracts and documents prepared while performing BWA contractual work are subject to the Arkansas Freedom of Information Act. If a Freedom of Information Act request is presented to the Beaver Watershed Alliance, the Consultant will do everything possible to provide the documents in a prompt and timely manner as prescribed in the Arkansas Freedom of Information Act (A.C.A. §25-19-101 et. seq.). Only legally authorized photocopying costs pursuant to the FOIA may be assessed for this compliance.
- c. Legal jurisdiction to resolve any disputes shall be Arkansas with Arkansas law applying to the case.

**13. BEAVER WATERSHED ALLIANCE INDEMNIFICATION:**

The successful Proposer(s) agrees to indemnify the BWA and hold it harmless from and against all claims, liability, loss, damage or expense, including but not limited to counsel fees, arising from or by reason of any actual or claimed trademark, patent or copyright infringement or litigation based thereon, with respect to the services or any part thereof covered by this order, and such obligation shall survive acceptance of the services and payment thereof by the BWA.

**14. VARIANCE FROM STANDARD TERMS and CONDITIONS:**

All standard terms and conditions stated in this request for proposals apply to this contract except as specifically stated in the subsequent sections of this document, which take precedence, and should be fully understood by Proposers prior to submitting a proposal on this requirement.

**15. PAYMENTS AND INVOICING:**

The Proposer must specify in their proposal the exact company name and address which must be the same as invoices submitted for payment as a result of award of this RFP. Further, the successful Proposer is responsible for immediately notifying the BWA of any company name change, which would cause invoicing to change from the name used at the time of the original RFP. Payment will be made within thirty days of invoice received. The Beaver Watershed Alliance is very credit-worthy and will not pay any interest or penalty for untimely payments. The BWA will not agree to allow any increase in hourly rates by the contract without PRIOR Beaver Watershed Alliance approval.

**16. CANCELLATION:**

- a. The BWA reserves the right to cancel this contract without cause by giving thirty (30) days prior notice to the vendor in writing of the intention to cancel or with cause if at any time the vendor fails to fulfill or abide by any of the terms or conditions specified.
- b. Failure of the vendor to comply with any of the provisions of the contract shall be considered a material breach of contract and shall be cause for immediate termination of the contract at the discretion of the Beaver Watershed Alliance.
- c. In addition to all other legal remedies available to the Beaver Watershed Alliance, the BWA reserves the right to cancel and obtain from another source any items and/or services which have not been delivered within the period of time from the date of order as determined by the Beaver Watershed Alliance.
- d. In the event sufficient budgeted funds are not available for a new fiscal period, the BWA shall notify the vendor of such occurrence and contract shall terminate on the last day of the current fiscal period without penalty or expense to the BWA.

**17. ASSIGNMENT, SUBCONTRACTING, CORPORATE ACQUISITIONS AND/OR MERGERS:**

- a. The selected Proposer shall perform this contract. No assignment of subcontracting shall be allowed without prior written consent of the BWA. If a Proposer intends to subcontract a portion of this work, the Proposer shall disclose such intent in the proposal submitted as a result of this RFP.
- b. In the event of a corporate acquisition and/or merger, the vendor shall provide written notice to the BWA within thirty (30) calendar days of vendor's notice of such action or upon the occurrence of said action, whichever occurs first. The right to terminate this contract, which shall not be unreasonably exercised by the BWA, shall include, but not be limited to, instances in which a corporate acquisition and/or merger represent a conflict of interest or are contrary to any local, state, or federal laws. Action by the BWA awarding a proposal to a firm that has disclosed its intent to assign or subcontract in its response to the RFP, without exception shall constitute approval for purpose of this Agreement.

**18. NON-EXCLUSIVE CONTRACT:**

Award of this RFP shall impose no obligation on the BWA to utilize the vendor for all work of this type, which may develop during the contract period. This is not an exclusive contract. The BWA specifically reserves the right to concurrently contract with other companies for similar work if it deems such an action to be in the BWA's best interest. In the case of multiple-phase contracts, this provision shall apply separately to each item.

## **19. ADDITIONAL REQUIREMENTS:**

The BWA reserves the right to request additional services relating to this RFP from the Proposer. When approved by the BWA as an amendment to the contract and authorized in writing prior to work, the vendor shall provide such additional requirements as may become necessary.

## **20. SERVICES AGREEMENT:**

A written agreement, in substantially the form attached, incorporating the RFP and the successful proposal will be prepared by the BWA, signed by the successful Proposer and presented to the Beaver Watershed Alliance for approval and signature of the Executive Director.

## **21. INTEGRITY OF REQUEST FOR PROPOSAL (RFP) DOCUMENTS:**

Proposers shall use the original RFP form(s) provided by the BWA and enter information only in the spaces where a response is requested. Proposers may use an attachment as an addendum to the RFP form(s) if sufficient space is not available on the original form for the Proposer to enter a complete response. **Any modifications or alterations to the original RFP documents by the Proposer, whether intentional or otherwise, may constitute grounds for rejection of such RFP response.** Any such modifications or alterations a Proposer wishes to propose shall be clearly stated in the Proposer's RFP response and presented in the form of an addendum to the original RFP documents.

## **22. LOBBYING:**

Lobbying or communicating with selection committee members, Beaver Watershed Alliance employees, or representatives regarding request for proposals, request for qualifications, bids or contracts, during the pendency of bid protest, by the bidder/proposer/protestor or any member of the bidder's/proposer's/protestor's staff, and agent of the bidder/proposer/protestor, or any person employed by any legal entity affiliated with or representing an organization that is responding to the request for proposal, request for qualification, bid or contract, or has a pending bid protest is **strictly prohibited** either upon advertisement or on a date established by the Beaver Watershed Alliance and shall be prohibited until either an award is final or the protest is finally resolved by the Beaver Watershed Alliance; provided, however, nothing herein shall prohibit a prospective/bidder/proposer from contacting the Beaver Watershed Alliance to address situations such as clarification and/or questions related to the procurement process. For purposes of this provision, lobbying activities or communication shall include but not be limited to, influencing or attempting to influence action or non-action in connection with any request for proposal, request for qualification, bid or contract through direct or indirect oral or written communication or an attempt to obtain goodwill of persons and/or entities specified in this provision. Such actions may cause any request for proposal, request for qualification, bid or contract to be rejected.

## **23. DEBARRED ENTITIES:**

By submitting a proposal, vendor states submitting entity is not a debarred contractor with the federal, any state, or local government.

## **24. OTHER GENERAL CONDITIONS:**

- a. Proposers shall provide the BWA with proposals signed by an employee having legal authority to submit proposals on behalf of the Proposer. The entire cost of preparing and providing responses shall be borne by the Proposer.
- b. The BWA reserves the right to request any additional information it deems necessary from any or all Proposers after the submission deadline.
- c. The request for qualifications is not to be construed as an offer, a contract, or a commitment of any kind; nor does it commit the BWA to pay for any costs incurred by Proposer in preparation. It shall be clearly understood that any costs incurred by the Proposer in responding to this request for proposals is at the Proposer's own risk and expense as a cost of doing business. The Beaver Watershed Alliance shall not be liable for reimbursement to the Proposer for any expense so incurred, regardless of whether or not the proposal is accepted.



- d. If products, components, or services other than those described in this bid document are proposed, the Proposer must include complete descriptive literature for each. All requests for additional information must be received within five working days following the request.
- e. **Any uncertainties shall be brought to the attention of Emily Finley immediately via telephone (479.502.4388) or e-mail ([emily@beaverwatershedalliance.org](mailto:emily@beaverwatershedalliance.org)). It is the intent and goal of the Beaver Watershed Alliance to provide documents providing a clear and accurate understanding of the scope of work to be completed and/or services to be provided. We encourage all interested parties to ask questions to enable all Proposers to be on equal terms.**
- f. Any inquiries or requests for explanation in regard to the BWA's requirements should be made promptly to Emily Finley, Beaver Watershed Alliance, via e-mail ([emily@beaverwatershedalliance.org](mailto:emily@beaverwatershedalliance.org)) or telephone (479.502.4388). No oral interpretation or clarifications will be given as to the meaning of any part of this request for proposals. All questions, clarifications, and requests, together with answers, if any, will be provided to all firms via written addendum. Names of firms submitting any questions, clarifications, or requests will not be disclosed until after a contract is in place.
- g. At the discretion of the BWA, one or more firms or teams may be asked for more detailed information before final ranking of the firms or teams, which may also include oral interviews.
- h. Any information provided herein is intended to assist the Proposer in the preparation of proposals necessary to properly respond to this RFP. The RFP is designed to provide qualified Proposers with sufficient basic information to submit proposals meeting minimum specifications and/or test requirements, but is not intended to limit a RFP's content or to exclude any relevant or essential data.
- i. Proposers irrevocably consent that any legal action or proceeding against it under, arising out of or in any manner relating to this Contract shall be controlled by Arkansas law. Proposer hereby expressly and irrevocably waives any claim or defense in any said action or proceeding based on any alleged lack of jurisdiction or improper venue or any similar basis.
- j. The successful Proposer shall not assign the whole or any part of this Contract or any monies due or to become due hereunder without written consent of Beaver Watershed Alliance. In case the successful Proposer assigns all or any part of any monies due or to become due under this Contract, the Instrument of assignment shall contain a clause substantially to the effect that is agreed that the right of the assignee in and to any monies due or to become due to the successful Proposer shall be subject to prior liens of all persons, firms, and corporations for services rendered or materials supplied for the performance of the services called for in this contract.
- k. The successful Proposer's attention is directed to the fact that all applicable Federal, State and Local laws or ordinances, and the rules and regulations of all authorities having jurisdiction over the services shall apply to the contract throughout, and they will be deemed to be included in the contract as though written out in full herein. The successful Proposer shall keep himself/herself fully informed of all laws, ordinances and regulations of the Federal, State, and Local governments or authorities in any manner affecting those engaged or employed in providing these services or in any way affecting the conduct of the services and of all orders and decrees of bodies or tribunals having any jurisdiction or authority over same. If any discrepancy or inconsistency should be discovered in these Contract Documents or in the specifications herein referred to, in relation to any such law, ordinance, regulation, order or decree, s/he shall herewith report the same in writing to Beaver Watershed Alliance.
- l. All contracting and construction services shall be completed and approved by both the Beaver Watershed Alliance and site property owner, including final walk-through and associated project modifications, no later than **July 31, 2025**.

## **25. INSURANCE:**

- a. Any project selected under this RFP shall require professional liability insurance in the amount of \$1 million US dollars, at minimum. Such Certificate of Insurance shall list the Beaver Watershed Alliance as an additional insured and not be required unless the firm is selected.

## **26. SELECTION CRITERIA:**

The evaluation criterion below defines the factors which will be used by the selection committee to evaluate and score responsive, responsible and qualified proposals. The evaluation factors are as follows:

1. **45 Points** – Capacity and capability of the firm or team to perform the work in question including specialized services, within the time limitations fixed for the completion of the projects
2. **35 Points** – Past record of performance of the firm or team with respect to such factors as control of costs, quality of work, and ability to meet schedules and deadlines
3. **20 Points** – Firm's or team's proximity to and familiarity with the area in which the projects are located

Beaver Watershed Alliance  
RFP 25-01, Low Impact Development Contracting Services  
SECTION B: Scope of Work

---

The work will generally consist of contracting services for the implementation of a demonstration LID project located within the Beaver Lake watershed. The project goal is to reduce Nonpoint Source (NPS) sediment and nutrient loads and improve water quality through the implementation of this demonstration LID project as a water quality Best Management Practice (BMP). Below is a description of the location and scope of the project:

1. Low Impact Development (LID) Parking Lot and Rain Gardens – Apartments at E Miracle Drive, Fayetteville, AR

This project aims to demonstrate low impact development features including permeable pavers and rain gardens by modifying existing infrastructure at the apartment complex at E Miracle Drive in Fayetteville, Arkansas. Permeable pavers are designed to intercept stormwater runoff, allowing stormwater to infiltrate and be treated. Rain gardens, planted with native plants, are designed to capture stormwater runoff from building roofs and adjacent pavement and allow it to infiltrate.

The City of Fayetteville is simultaneously improving public stormwater infrastructure near and through the apartment site in the existing utility easement.

Beaver Watershed Alliance  
RFP 25-01, Low Impact Development Contracting Services  
SECTION C: Firm Organizational Summary and References

---

**ATTENTION: This form shall be completed and returned with EACH SUBMITTED Proposal. The BWA will utilize the selection marked by each firm or team of firms to correspond with the scope of work for each project.**

**NAME OF PRIMARY FIRM:** \_\_\_\_\_

NUMBER OF YEARS IN BUSINESS: \_\_\_\_\_ HOW LONG IN PRESENT LOCATION: \_\_\_\_\_

TOTAL NUMBER OF CURRENT EMPLOYEES: \_\_\_\_\_ FULL TIME \_\_\_\_\_ PART TIME

NUMBER OF EMPLOYEES PLANNED FOR THIS CONTRACT: \_\_\_\_\_ FULL TIME \_\_\_\_\_ PART TIME

ROLE IN THE PROJECT: \_\_\_\_\_

---

---

PLEASE LIST THREE (3) REFERENCES THAT YOU HAVE PREVIOUSLY PERFORMED CONTRACT SERVICES FOR WITHIN THE PAST FIVE (5) YEARS (All fields must be completed):

1. \_\_\_\_\_  
COMPANY NAME

\_\_\_\_\_  
CITY, STATE, ZIP

\_\_\_\_\_  
CONTACT PERSON

\_\_\_\_\_  
TELEPHONE

\_\_\_\_\_  
FAX NUMBER

\_\_\_\_\_  
E-MAIL ADDRESS

2. \_\_\_\_\_  
COMPANY NAME

\_\_\_\_\_  
CITY, STATE, ZIP

\_\_\_\_\_  
CONTACT PERSON

\_\_\_\_\_  
TELEPHONE

\_\_\_\_\_  
FAX NUMBER

\_\_\_\_\_  
E-MAIL ADDRESS

**PRIMARY FIRM REFERENCES CONTINUED:**

3. \_\_\_\_\_  
COMPANY NAME

\_\_\_\_\_  
CITY, STATE, ZIP

\_\_\_\_\_  
CONTACT PERSON

\_\_\_\_\_  
TELEPHONE

\_\_\_\_\_  
FAX NUMBER

\_\_\_\_\_  
E-MAIL ADDRESS

4. \_\_\_\_\_  
COMPANY NAME

\_\_\_\_\_  
CITY, STATE, ZIP

\_\_\_\_\_  
CONTACT PERSON

\_\_\_\_\_  
TELEPHONE

\_\_\_\_\_  
FAX NUMBER

\_\_\_\_\_  
E-MAIL ADDRESS

**ATTENTION: This form shall be completed and returned for each firm, company and/or individual included in the proposal.**

**NAME OF FIRM:** \_\_\_\_\_

NUMBER OF YEARS IN BUSINESS: \_\_\_\_\_ HOW LONG IN PRESENT LOCATION: \_\_\_\_\_

TOTAL NUMBER OF CURRENT EMPLOYEES: \_\_\_\_\_ FULL TIME \_\_\_\_\_ PART TIME

NUMBER OF EMPLOYEES PLANNED FOR THIS CONTRACT: \_\_\_\_\_ FULL TIME \_\_\_\_\_ PART TIME

ROLL IN THE PROJECT: \_\_\_\_\_

PLEASE LIST THREE (3) REFERENCES THAT YOU HAVE PREVIOUSLY PERFORMED CONTRACT SERVICES FOR WITHIN THE PAST FIVE (5) YEARS (All fields must be completed):

1. \_\_\_\_\_  
COMPANY NAME

\_\_\_\_\_  
CITY, STATE, ZIP

\_\_\_\_\_  
CONTACT PERSON

\_\_\_\_\_  
TELEPHONE

\_\_\_\_\_  
FAX NUMBER

\_\_\_\_\_  
E-MAIL ADDRESS

3. \_\_\_\_\_  
COMPANY NAME

\_\_\_\_\_  
CITY, STATE, ZIP

\_\_\_\_\_  
CONTACT PERSON

\_\_\_\_\_  
TELEPHONE

\_\_\_\_\_  
FAX NUMBER

\_\_\_\_\_  
E-MAIL ADDRESS

2. \_\_\_\_\_  
COMPANY NAME

\_\_\_\_\_  
CITY, STATE, ZIP

\_\_\_\_\_  
CONTACT PERSON

\_\_\_\_\_  
TELEPHONE

\_\_\_\_\_  
FAX NUMBER

\_\_\_\_\_  
E-MAIL ADDRESS

4. \_\_\_\_\_  
COMPANY NAME

\_\_\_\_\_  
CITY, STATE, ZIP

\_\_\_\_\_  
CONTACT PERSON

\_\_\_\_\_  
TELEPHONE

\_\_\_\_\_  
FAX NUMBER

\_\_\_\_\_  
E-MAIL ADDRESS

**1. Disclosure Information**

Proposer must disclose any possible conflict of interest with the Beaver Watershed Alliance, including, but not limited to, any relationship with any Beaver Watershed Alliance employee. Proposer response must disclose if a known relationship exists between any principal or employee of your firm and any Beaver Watershed Alliance employee or Beaver Watershed Alliance representative.

If, to your knowledge, no relationship exists, this should also be stated in your response. Failure to disclose such a relationship may result in cancellation of a purchase and/or contract as a result of your response. This form must be completed and returned in order for your bid/proposal to be eligible for consideration.

**PLEASE CHECK ONE OF THE FOLLOWING TWO OPTIONS, AS IT APPROPRIATELY APPLIES TO YOUR FIRM:**

\_\_\_\_\_ 1) NO KNOWN RELATIONSHIP EXISTS

\_\_\_\_\_ 2) RELATIONSHIP EXISTS (Please explain): \_\_\_\_\_

I certify that; as an officer of this organization, or per the attached letter of authorization, I am duly authorized to certify the information provided herein as accurate and true; and my organization shall comply with all State and Federal Equal Opportunity and Non-Discrimination requirements and conditions of employment.

**2. Additional Information**

At the discretion of the BWA, one or more firms or teams may be asked for more detailed information before final ranking of the firms, which may also include oral interviews. **NOTE: Each Proposer shall submit to the BWA a primary contact name, e-mail address, and phone number (preferably a cell phone number) where the BWA selection committee can call for clarification or interview via telephone.**

Name of Firm: \_\_\_\_\_

Name of Primary Contact: \_\_\_\_\_

Title of Primary Contact: \_\_\_\_\_

Phone#1 (cell preferred): \_\_\_\_\_

Phone #2: \_\_\_\_\_

E-Mail Address: \_\_\_\_\_

3. Please acknowledge receipt of addenda for this request for proposals by signing and dating below. All addenda are hereby made a part of the RFP documents to the same extent as though it were originally included therein. Proposers should indicate their receipt of same in the appropriate blank listed herein. Failure to do so may subject vendor to disqualification.

ADDENDUM NO.	SIGNATURE AND PRINTED NAME	DATE ACKNOWLEDGED

4. As an interested party on this project, you are required to provide debarment/suspension certification indicating in compliance with the below Federal Executive Order. Certification can be done by completing and signing this form.

Federal Executive Order (E.O.) 12549 "Debarment and Suspension" requires that all contractors receiving individual awards, using federal funds, and all sub-recipients certify that the organization and its principals are not debarred, suspended, proposed for debarment, declared ineligible, or voluntarily excluded by any Federal department or agency from doing business with the Federal Government.

5. Signature certifies that neither you nor your principal is presently debarred, suspended, proposed for debarment, declared ineligible, or voluntarily excluded from participation in this transaction by any federal department or agency.

**Questions regarding this form should be directed to the Beaver Watershed Alliance.**

NAME: \_\_\_\_\_

COMPANY: \_\_\_\_\_

PHYSICAL ADDRESS: \_\_\_\_\_

MAILING ADDRESS: \_\_\_\_\_

PHONE: \_\_\_\_\_ FAX: \_\_\_\_\_

E-MAIL: \_\_\_\_\_



Signed by:

SIGNATURE: \_\_\_\_\_

PRINTED NAME : \_\_\_\_\_

TITLE: \_\_\_\_\_

DATE: \_\_\_\_\_

## APPENDIX A

# Low Impact Development (LID) Parking Lot and Rain Gardens – Apartments at E Miracle Drive, Fayetteville, AR



*Figure 1: Site photo of existing drive (S Grace Ave).*



Figure 2: Site photo of existing drive (E Miracle Drive).

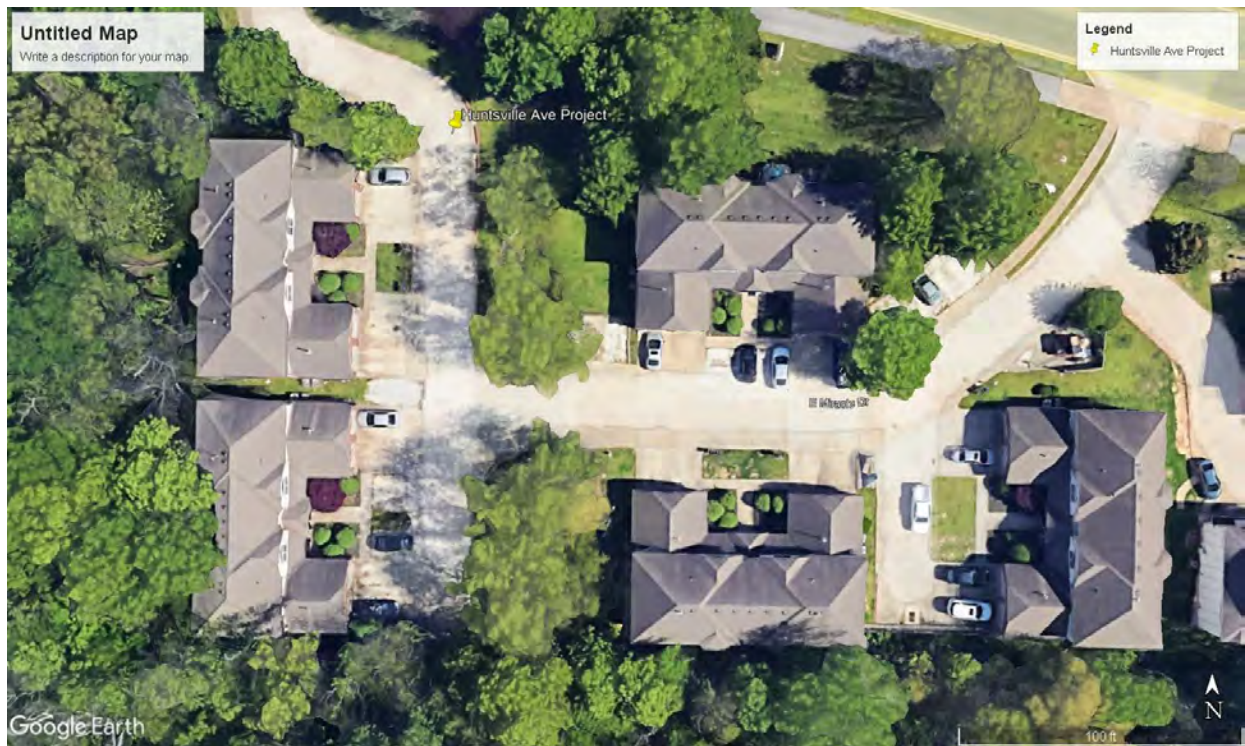

Figure 3: Aerial image of site (credit: Google Earth).

# Miracle Avenue

## Fayetteville, Arkansas Low Impact Development Plan

PREPARED FOR:



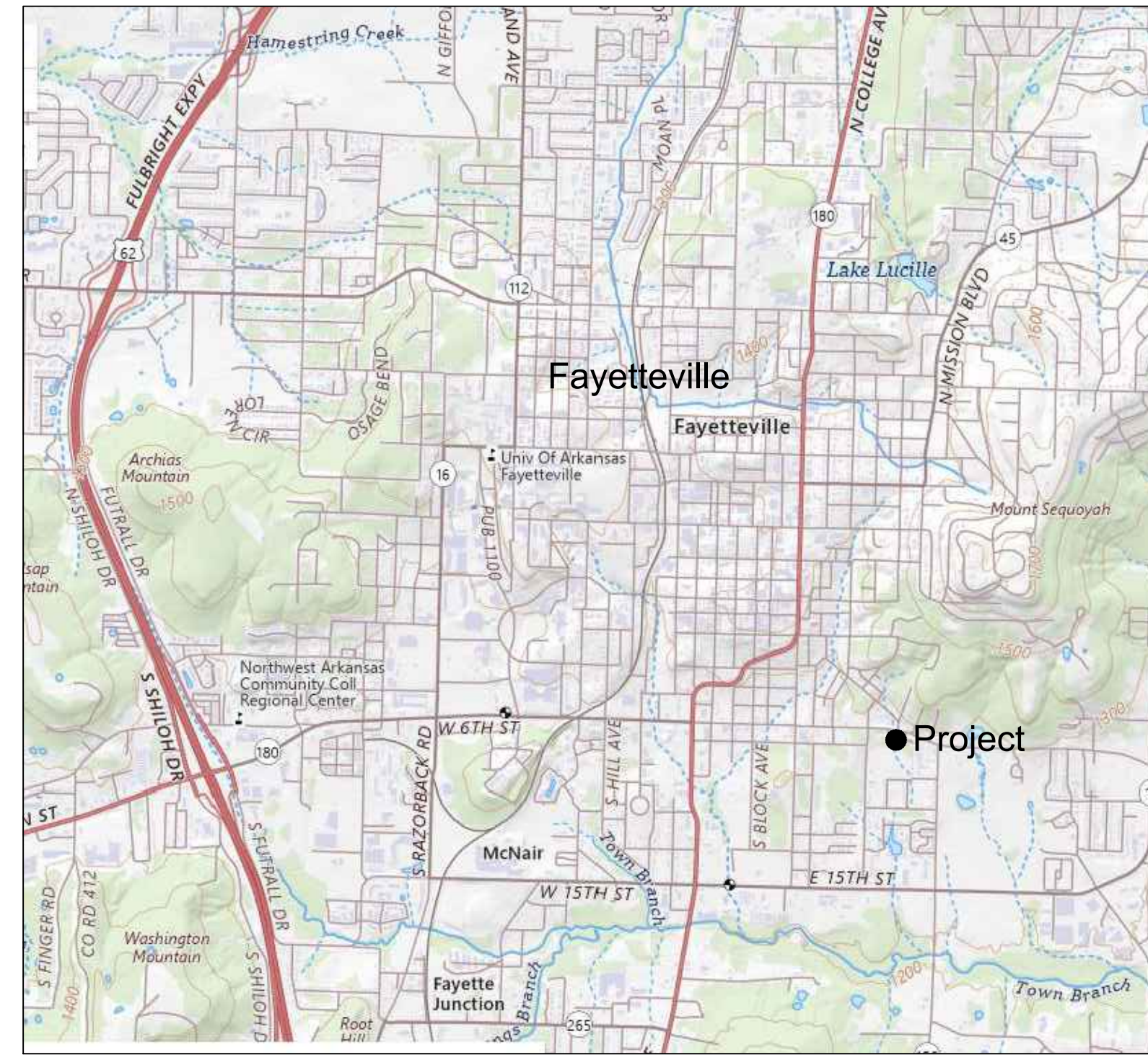

### Beaver Watershed Alliance



VICINITY MAP

INDEX OF SHEETS:

- C100 COVER SHEET
- C101 GENERAL NOTES
- C102 EXISTING CONDITIONS WITH KNOWN UTILITIES
- C103 DEMOLITION PLAN
- C104 SITE PLAN WITH IMPROVEMENTS
- C105 BIOSWALE &, PERMEABLE PAVERS PLAN
- C106 TYPICAL DETAILS
- C107 STORMWATER BMP'S

Revs:	Date:	<b>CONSULTANT</b>  <b>CIVIL ENGINEER</b> HODGES ENGINEERING 15364 TWIN PINES ROAD LOWELL, AR 72745 (479) 713-0341				Drawing Title	Phase	Project Title	Project Number
						<b>COVER SHEET</b>	<b>PERMEABLE PAVEMENT &amp; BIOSWALE PLAN</b>	<b>MIRACLE AVENUE LOW IMPACT DEVELOPMENT PLAN</b>	<b>2024-07</b>
								Location	Drawing Number
			<b>FAYETTEVILLE, ARKANSAS</b>	<b>C100</b>					
			Issue Date	Checked	Drawn				
			2024.08.01	KEH	KEH				

A  
B  
C  
D  
E  
F

**General**

1. This Plan is intended as a Design-Build with Beaver Watershed Alliance (BWA).
2. Coordinate sequencing of construction with BWA and Engineer to minimize impact to residents.
3. Work Shall be performed by an experience licensed contractor using applicable building codes, and industry accepted standard practices.
4. Contractor shall comply with requirements of all applicable regulatory agencies.
5. All locations, dimensions & elevations shown are approximate & should be field verified. Contractor will notify Engineer of any discrepancies prior to start of construction.
6. A boundary survey was not Provided.
7. Construction methods are not indicated on these drawing. The contractor shall be solely responsible for all methods, sequences, and procedures of construction. The contractor shall provide adequate shoring, bracing, formwork, etc. a required for the protection of life and property during construction.
8. Excavation procedures, including shoring and protection of adjacent property, structures, street and utilities, shall be performed in compliance with local building codes, regulations and safety requirement, and shall be the contractors responsibility.
9. Locate all utilities prior to beginning construction.
10. Concrete Apron F'c=3,500 psi, saw cut every 15', +/-2' depth.
11. Periodic observations and monitoring by the Engineer is recommended.

**Bioswale Notes:**



1. Prior to placing the course sand with underdrain and the bioretention soil mixture (BSM), the bottom of the swale shall be roto tilled to a minimum of 6 inches.
2. 4 inches Min. of Course sand ASTM C-33 and the underdrain system shall be placed on the structural fill.
3. 6 inches Min. of BSM shall be placed over the course sand and underdrain system, the BSM shall be uncompacted and shall consist of:
  - 3.1. 50-85% Sand (2.0-0.05 mm) AASHTO T88
  - 3.2. 0-50% Silt (0.05-0.002 mm) AASHTO T88
  - 3.3. 10-20% Clay (less than 0.002 mm) AASHTO T88
  - 3.4. 1.5-10% Organic Matter (Compost) AASHTO T194
4. All plants shall be Native and conform to the standards of American Standard for Nursery Stock, approved plants include but not limited to:
  - 4.1. Blue Flag
  - 4.2. Prairie Dropseed
  - 4.3. Blue False Indigo
  - 4.4. Muhly Grass
  - 4.5. Winkle-leaf Goldenrod
  - 4.6. Yucca Arkansana
  - 4.7. Little Bluestem
  - 4.8. Indian Grass
  - 4.9. Black-eyed Susan
  - 4.10. Butterfly Milkweed
  - 4.11. Fox Sedge
  - 4.12. Blue Lobelia
5. Plants shall be planted +/-3 feet on Centers.
6. Flagstone Trickle Channel shall consist of natural thin veneer stone with a Typ. width of 2 feet:
  - 6.1. Flagstone thickness shall be 3/4" to 1-1/2"
  - 6.2. Top of Flagstone will be placed flush with the bioswale surface.

**Landscape Notes**

1. Prior to landscape installation, review the subsurface drainage conditions. Install materials "high" if necessary, due to subsurface conditions. Contact the General Contractor if existing conditions might jeopardize the plant materials' livability. Provide positive drainage of the subgrade in all turf areas and mass planting areas.
2. Provide positive drainage away from the building in all areas and provide smooth, continuous grades.
3. Stake the location of all mass planting areas and obtain approval of the BWA prior to installation.
4. Review the utility plans prior to installing the plant materials.
5. All container grown material shall be thoroughly hand watered upon arrival, while in the containers, before planting.
6. All exterior mass planting and groundcover beds are to be full with material equally spaced, at the designated "on-center" spacing, at the time of planting.
7. Re-sod any areas disturbed along property line or edge of scope of work. Coordinate work with BWA. Provide smooth transition to existing grades not within scope of work.
8. Protect existing sod during landscape installation. Re-sod any areas disturbed. Provide smooth transition to existing turf with new solid sod. Any additional sod is to be laid on a smooth uniform grade with all joints tight and even. Match sod with existing turf.
9. Provide smooth transition from new areas of sod to existing sod areas to remain.
10. Provide temporary irrigation, by water trucks or other means, as required for sod establishment and maintenance as per the specifications and general notes. No permanent irrigation system shall be installed for sod areas. All temporary irrigation equipment shall be removed at the end of the plant establishment period. Provide a permanent drip bubbler irrigation system for all groundcover within scope of work or as directed by BWA.

**Groundcover Planting Notes:**

1. Provide weed control and/or fertilizer as specified.
2. Weed control & Fertilizer may be applied at a later date to comply with seasonal conditions and growing period.
3. Provide slow release fertilizer tablets per manufacturers recommendations.
4. Provide homogenous backfill planting mixture as specified.
5. Provide root stimulator or approved equal in holes for plants.
6. Apply rpeemergent weed control or approved equal on all shrub and groundcover beds.

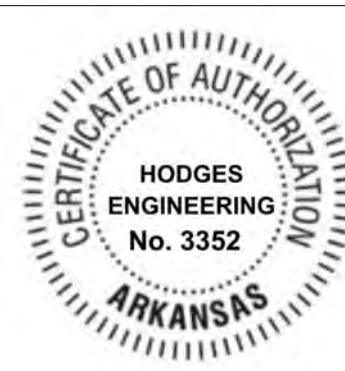
<p>Revs:</p>	<p>Date:</p>	<p><b>CONSULTANT</b></p> <p>Hodges Engineering</p>  <p><b>CIVIL ENGINEER</b></p> <p>HODGES ENGINEERING 15364 TWIN PINES ROAD LOWELL, AR 72745 (479) 713-0341</p>				<p>Drawing Title</p> <p><b>GENERAL NOTES</b></p>	<p>Phase</p> <p><b>PERMEABLE PAVEMENT &amp; BIOSWALE PLAN</b></p>	<p>Project Title</p> <p><b>MIRACLE AVENUE LOW IMPACT DEVELOPMENT PLAN</b></p>	<p>Project Number</p> <p><b>2024-07</b></p>	
								<p>Location</p> <p><b>FAYETTEVILLE, ARKANSAS</b></p>	<p>Drawing Number</p> <p><b>C101</b></p>	
								<p>Issue Date</p> <p>2024.08.01</p>	<p>Checked</p> <p>KEH</p>	<p>Drawn</p> <p>KEH</p>

GENERAL NOTES:  
 1. All underground utilities may not be shown.  
 2. Contact Arkansas One Call prior to any Excavation at 811, 1-800-482-8998, or file an eTicket at arkansas811.com.  
 3. Utilities shown are at an unknown depth.  
 4. The project is partially located within the 100 year flood plain.  
 5. Utilities & Contours shown on these plans are from the City of Fayetteville GIS.

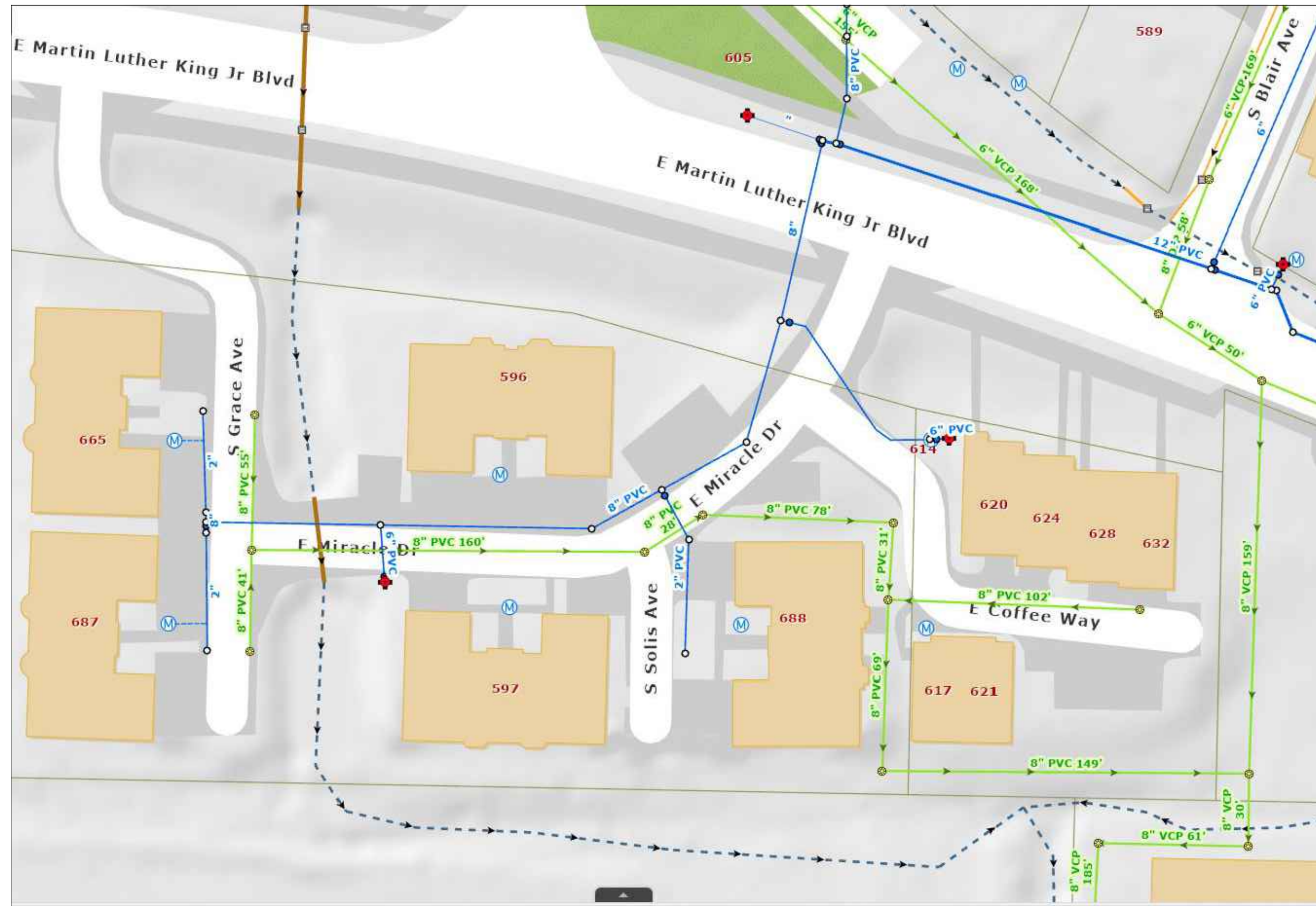

Known Utilities-City of Fayetteville GIS



FEMA Floodplain Map

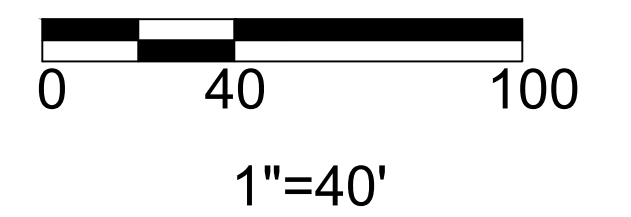
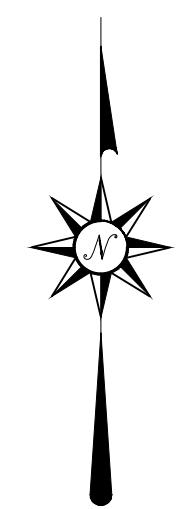

Revs:	Date:	<b>CONSULTANT</b> Hodges Engineering  <b>CIVIL ENGINEER</b> HODGES ENGINEERING 15384 TWIN PINES ROAD LOWELL, AR 72745 (479) 713-0341				Drawing Title	Phase	Project Title	Project Number	
							EXISTING CONDITIONS PERMEABLE PAVEMENT & BIOSWALE PLAN	MIRACLE AVENUE LOW IMPACT DEVELOPMENT PLAN	2024-07	
						Location	Issue Date	Checked	Drawn	Drawing Number
						FAYETTEVILLE, ARKANSAS	2024.08.01	KEH	KEH	C102

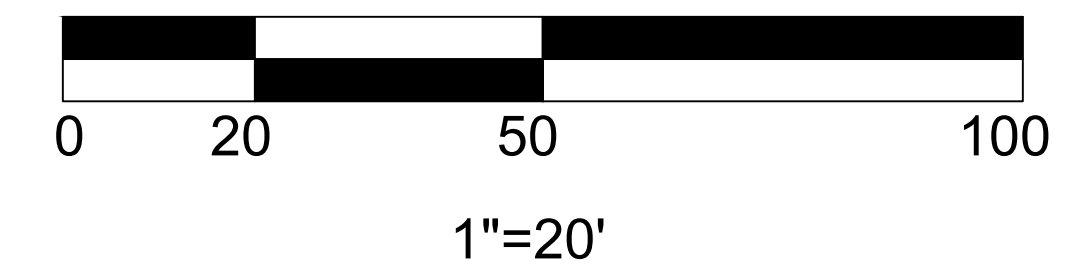
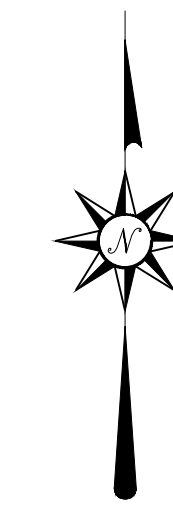

Revs:	Date:

**CONSULTANT**  
 Hodges Engineering  
  
**CIVIL ENGINEER**  
 HODGES ENGINEERING  
 15364 TWIN PINES ROAD  
 LOWELL, AR 72745  
 (479) 713-0341

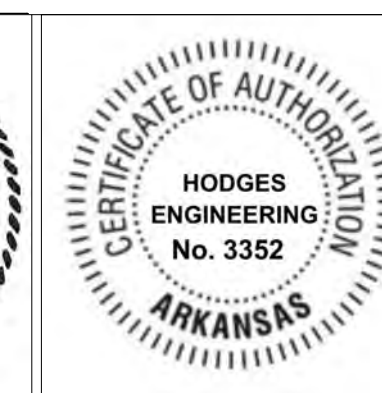
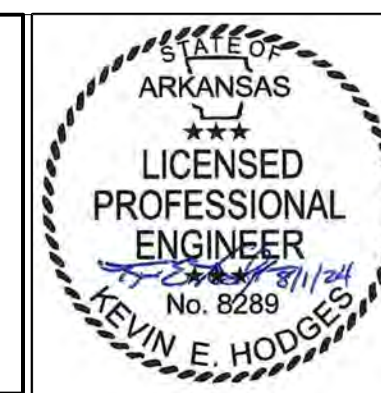

Drawing Title  
**DEMOLITION PLAN**

Phase  
**PERMEABLE PAVEMENT & BIOSWALE DESIGN**

Project Title  
**MIRACLE AVENUE LOW IMPACT DEVELOPMENT PLAN**

Location  
**FAYETTEVILLE, ARKANSAS**

Issue Date  
 2024.08.01

Checked  
 KEH

Drawn  
 KEH

Project Number  
**2024-07**

Drawing Number  
**C103**



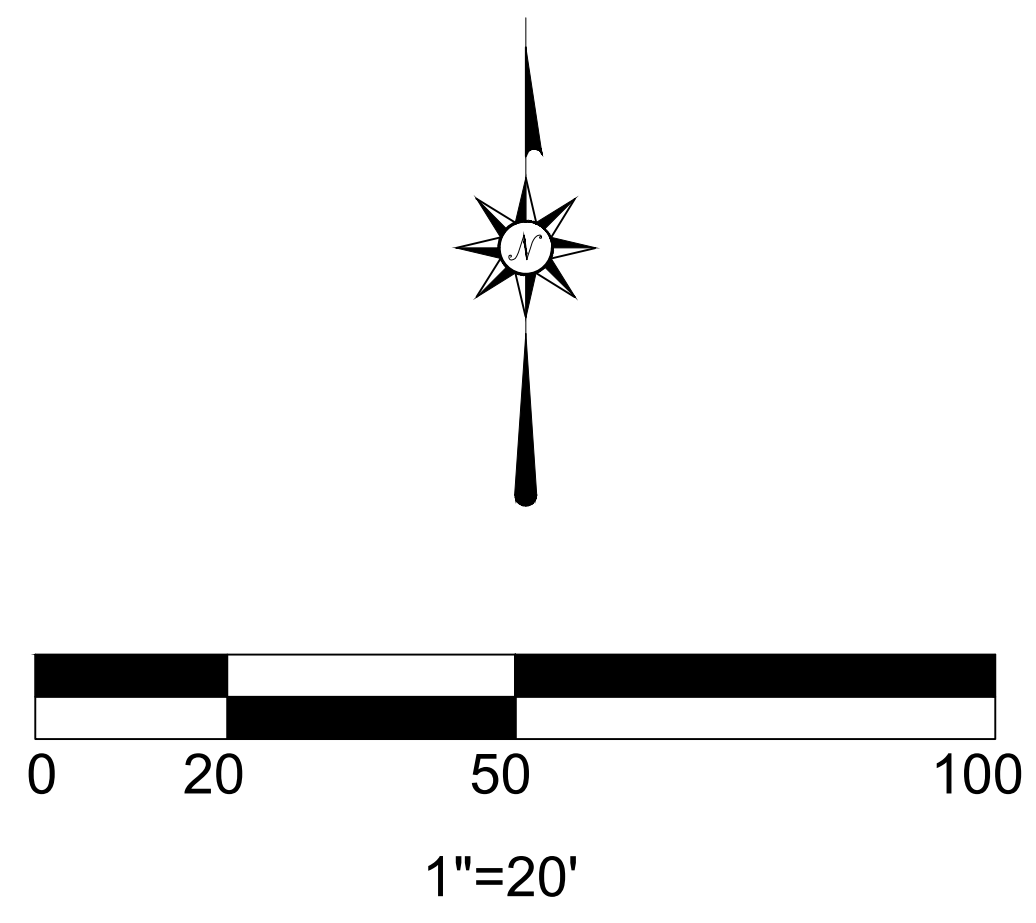
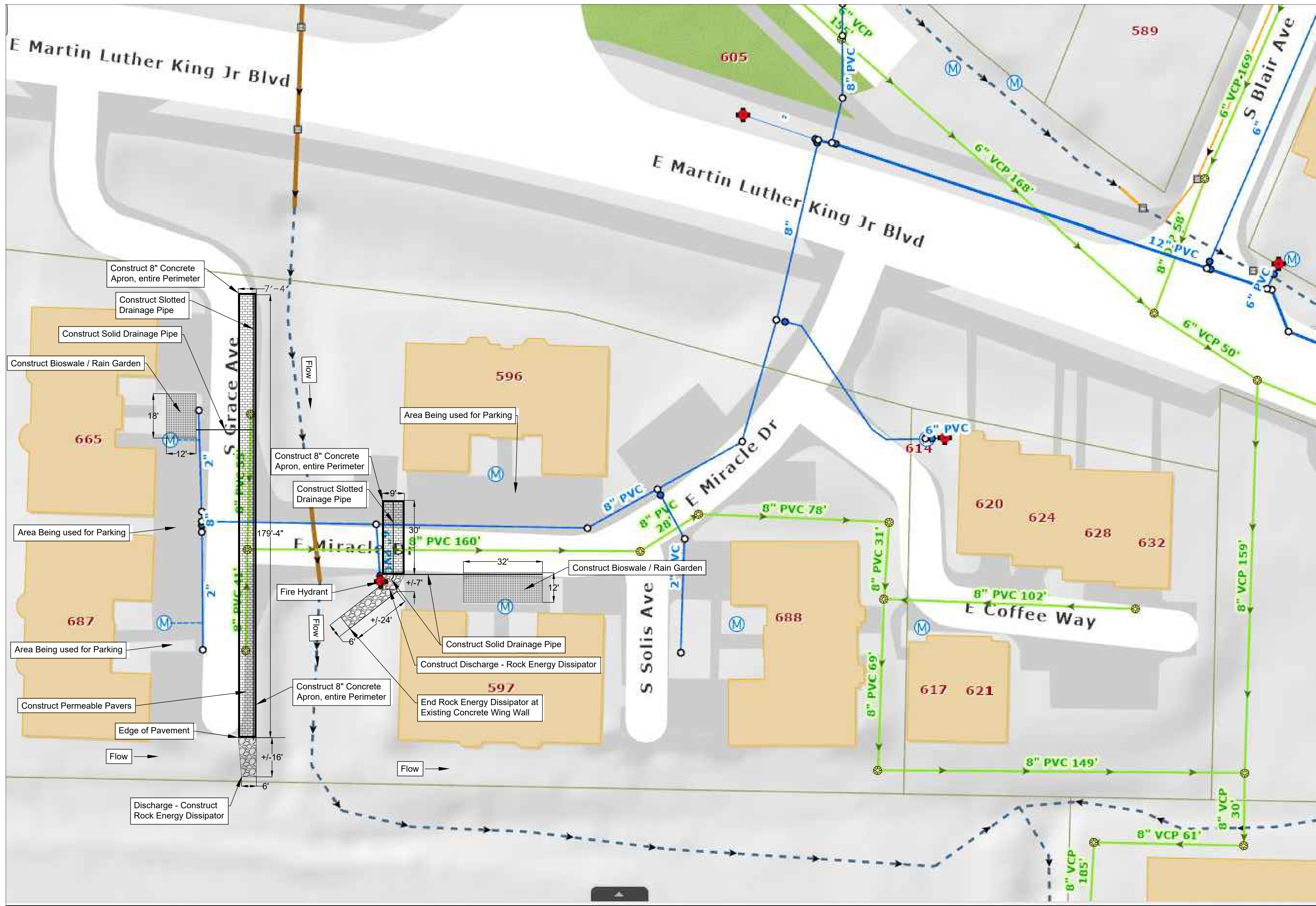

Revs:	Date:

**CONSULTANT**  
 Hodges Engineering  
  
**CIVIL ENGINEER**  
 HODGES ENGINEERING  
 13264 TWIN PINES ROAD  
 LOWELL, AR 72745  
 (479) 713-0341

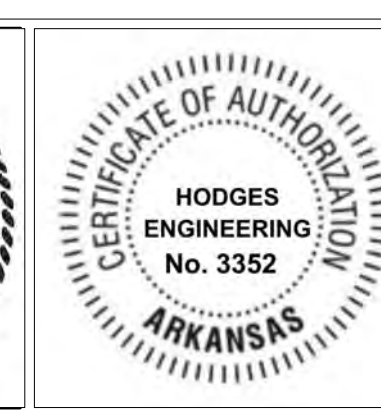

Drawing Title	<b>SITE PLAN</b>
Phase	<b>PERMEABLE PAVEMENT &amp; BIOSWALE DESIGN</b>

Project Title	<b>MIRACLE AVENUE LOW IMPACT DEVELOPMENT PLAN</b>	Project Number	<b>2024-07</b>
Location	<b>FAYETTEVILLE, ARKANSAS</b>	Drawing Number	<b>C104</b>
Issue Date	2024.08.01	Checked	KEH
		Drawn	KEH

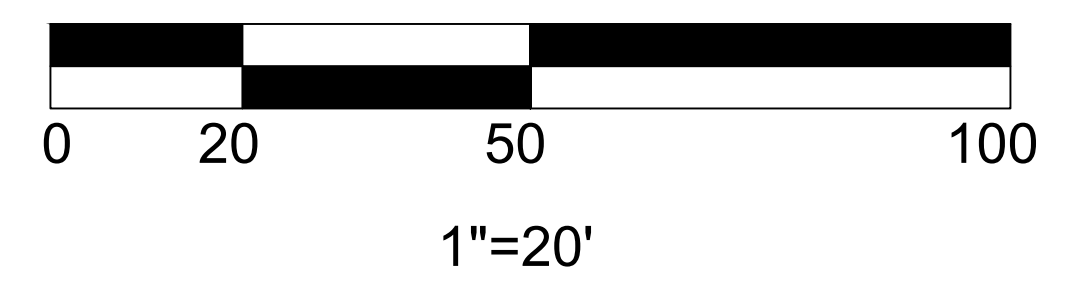
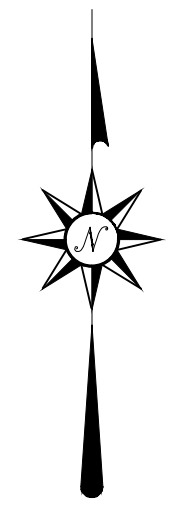

Revs:	Date:

**CONSULTANT**  
 Hodges Engineering  
  
**CIVIL ENGINEER**  
 HODGES ENGINEERING  
 15264 TWIN PINES ROAD  
 LOWELL, AR 72745  
 (479) 713-0341

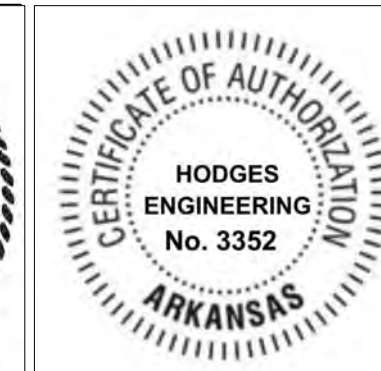

Drawing Title <b>BIOSWALE &amp; PERMEABLE PAVEMENT PLAN</b>

Phase <b>PERMEABLE PAVEMENT &amp; BIOSWALE DESIGN</b>

Project Title <b>MIRACLE AVENUE LOW IMPACT DEVELOPMENT PLAN</b>		
Location <b>FAYETTEVILLE, ARKANSAS</b>		
Issue Date 2024.08.01	Checked KEH	Drawn KEH

Project Number <b>2024-07</b>
Drawing Number <b>C105</b>

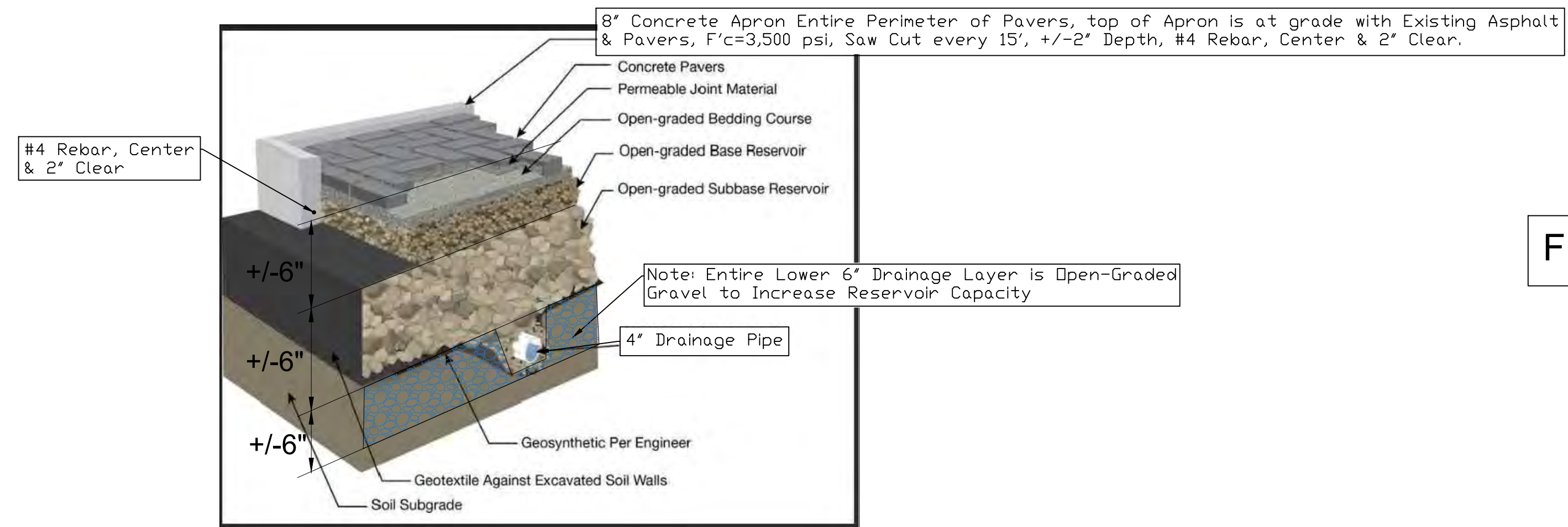

**Permeable Paver Detail**  
NTS

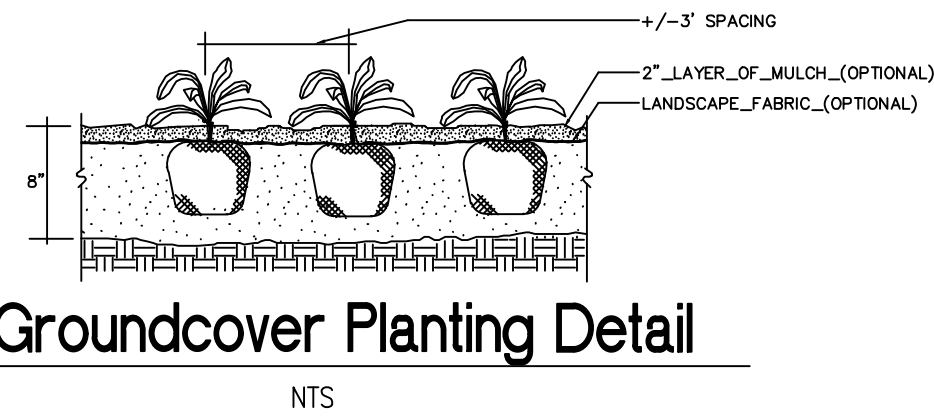

**Groundcover Planting Detail**  
NTS

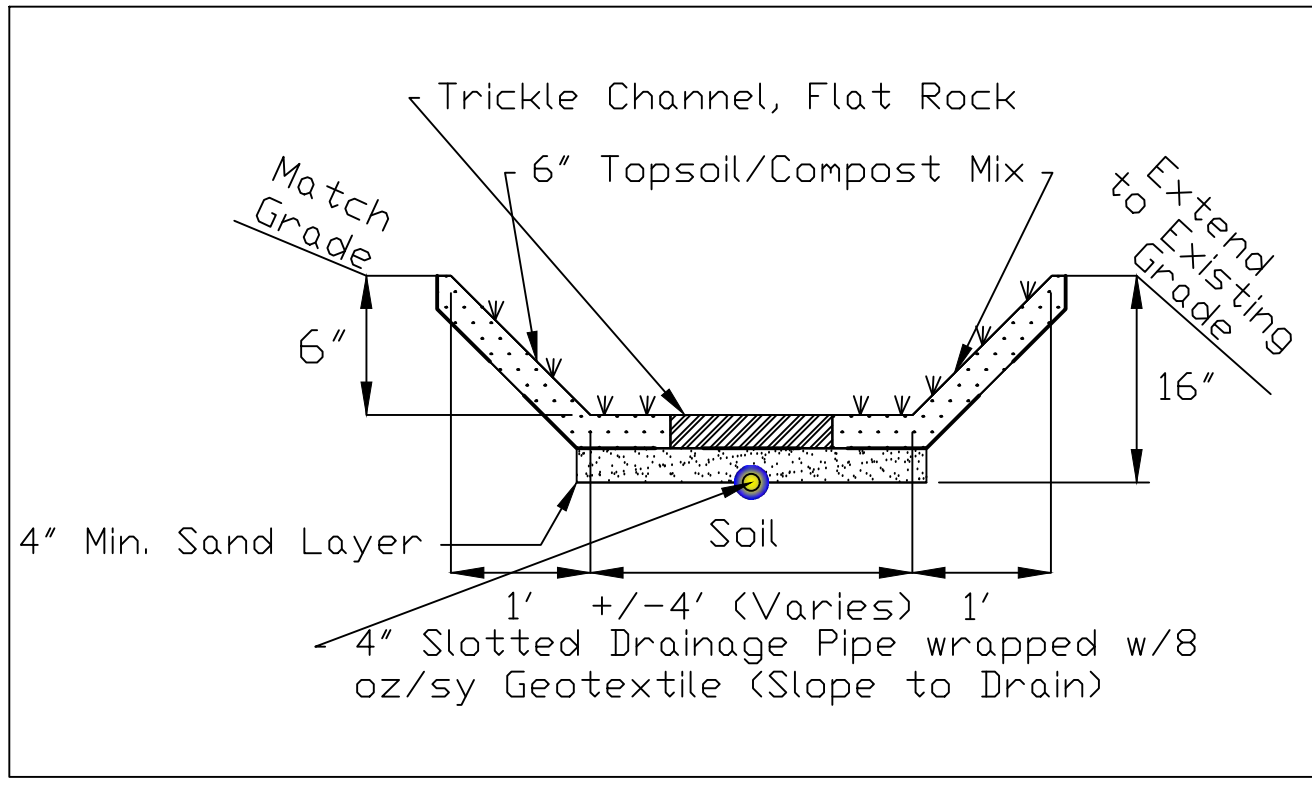

**Bioswale Detail**  
NTS

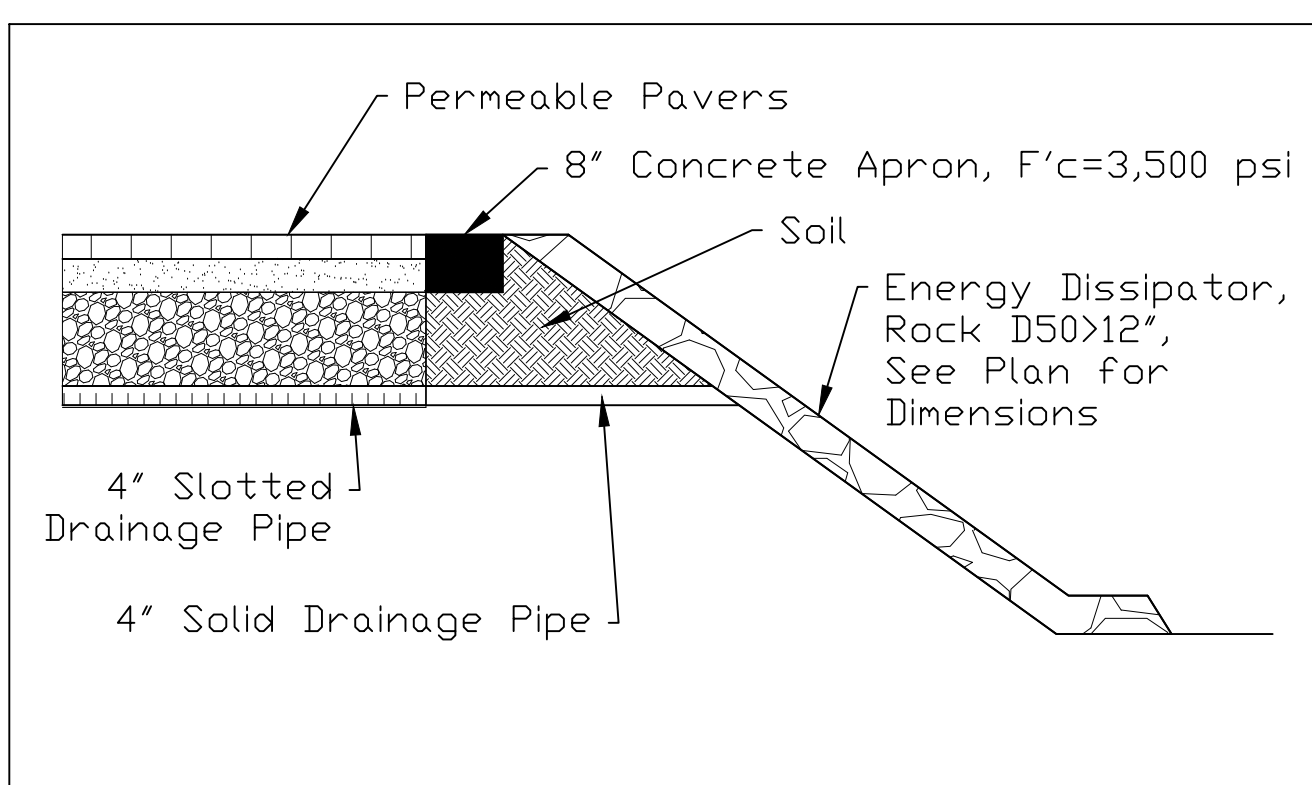

**Permeable Pavers at Energy Dissipator Detail**  
NTS

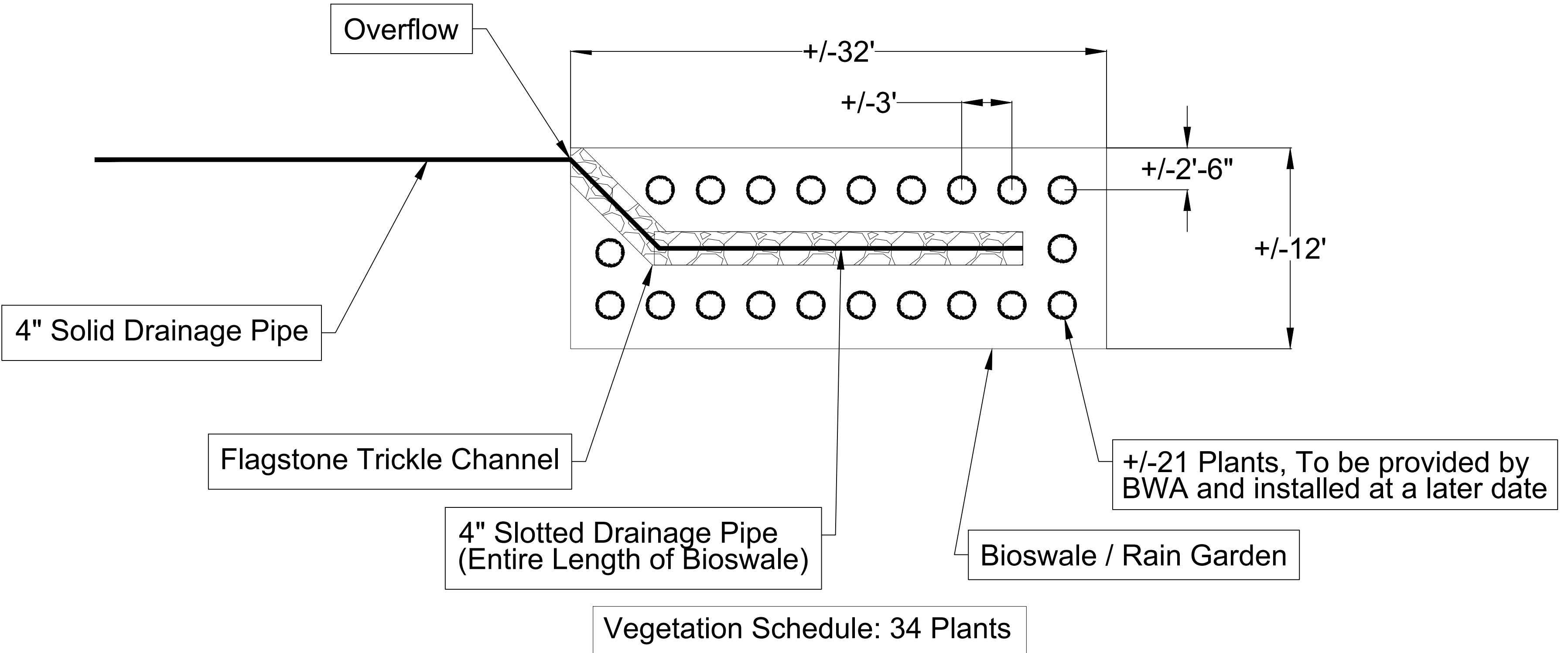
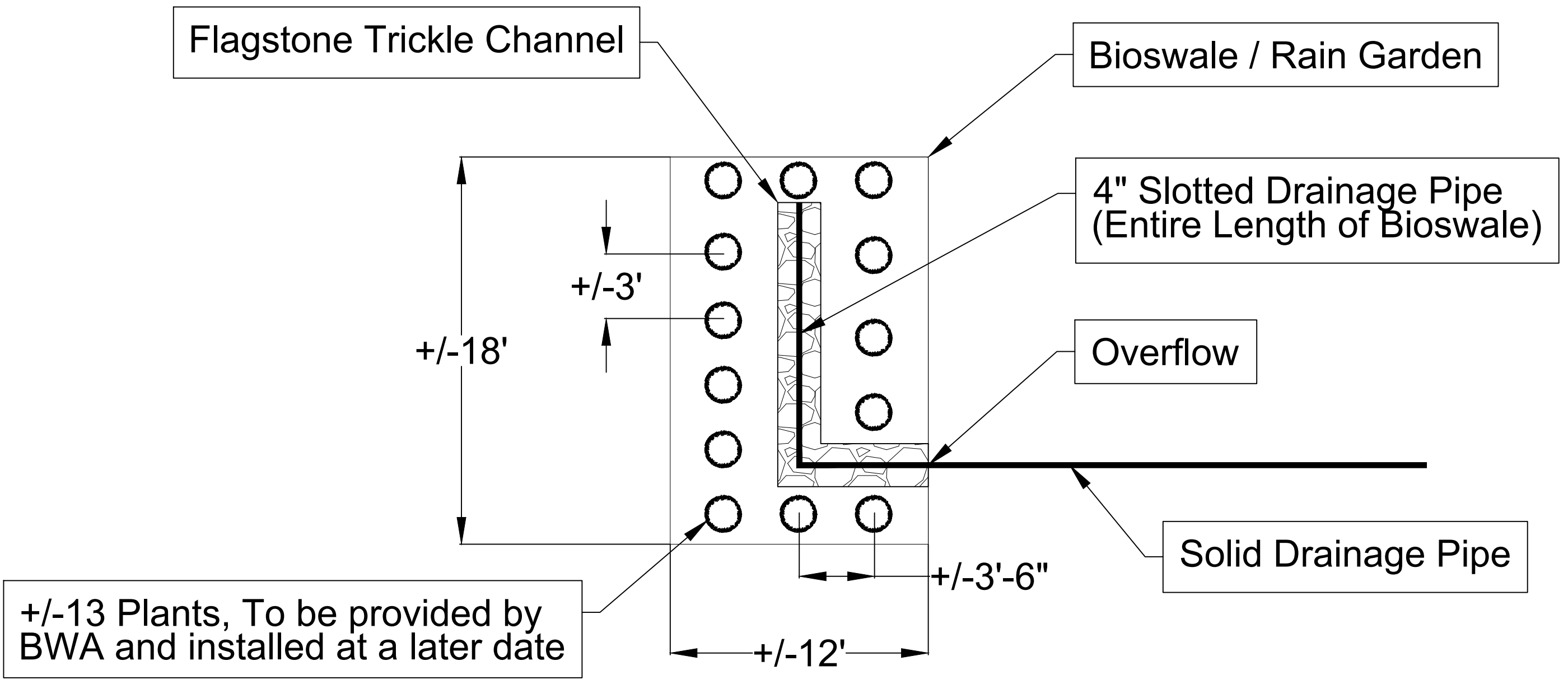

**Bioswale Plan**  
NTS

Revs:	Date:

**CONSULTANT**  
Hodges Engineering  
  
**CIVIL ENGINEER**  
HODGES ENGINEERING  
15264 TWIN PINES ROAD  
LOWELL, AR 72745  
(479) 713-0341

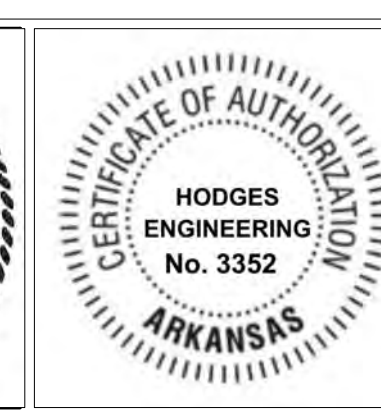

Drawing Title <b>Typical Details</b>

Phase <b>PERMEABLE PAVEMENT &amp; BIOSWALE DESIGN</b>

Project Title <b>MIRACLE AVENUE LOW IMPACT DEVELOPMENT PLAN</b>		
Location <b>FAYETTEVILLE, ARKANSAS</b>		
Issue Date 2024.08.01	Checked KEH	Drawn KEH

Project Number 2024-07
Drawing Number <b>C106</b>

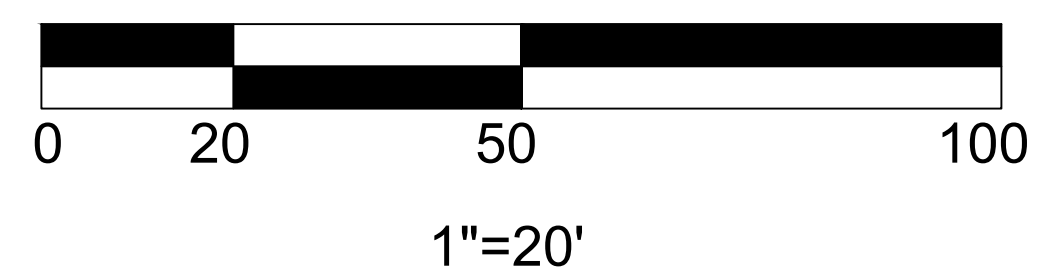
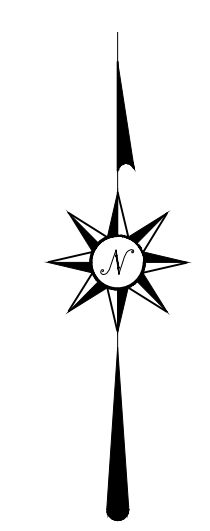

Maximum Slope Length for Silt Fence		
Slope Percent	Max. Slope Length (Ft) Above Fence	Max. Slope Length (Ft) Below Fence
5	150	250
10	75	150
15	50	100
20	35	75
25	25	50
30	15	40
35	10	30
40	10	25
45	10	20
50	10	15

NOTES:  
 1. THE SLOPE LENGTH SHOWN IS THE DISTANCE FROM THE FENCE TO THE CHANNEL EDGE IN THE NEAREST UPRIGHT CHANNEL.  
 2. SLOPE LENGTH CANNOT BE ADDRESSED BY USE OF MULTIPLE ROWS OF SILT FENCE.

INSTALLATION NOTES:  
 1. POSTS WHICH SUPPORT THE SILT FENCE SHALL BE INSTALLED ON A SLIGHT ANGLE TOWARD THE ANTICIPATED DIRECTION OF FLOW.  
 2. THE TOP OF THE SILT FENCE SHALL BE TRENCHED IN WITH A SPADE OR MECHANICAL TRENCHER, SO THAT THE REMOVAL OF POSTS WILL BE EVIDENCED A MINIMUM OF ONE FOOT.  
 3. THE FACE OF THE TRENCH IS FLAT AND PERPENDICULAR TO THE LINE OF FLOW. WHEN FENCE CANNOT BE TRENCHED IN (e.g. PAVEMENT), WEIGHT FABRIC FLAP WITH SOEDS OR APRON, SIZE TO PREVENT FLOW FROM SEEPING UNDER FENCE.  
 4. THE TRENCH MUST BE A MINIMUM OF 4 INCHES DEEP AND 4 INCHES WIDE TO ALLOW FOR THE SILT FENCE FABRIC TO BE LAYED ON (INCLUDING OVERLAP) AND FULFILL WITH COMPACTED MATERIAL.  
 5. ADJACENT ROLLS SHALL BE INSTALLED ON CENTER WITH A SLIGHT UPWARD CURVE AT THE END OF THE FABRIC.  
 6. REPAIR OR REPLACEMENT SHALL BE MADE PROMPTLY AS NEEDED, STABILIZED SO AS NOT TO BLOCK OR IMPED FLOW OF RUNOFF.  
 7. ACCUMULATED SEDIMENT SHALL BE REMOVED WHEN IT REACHES A DEPTH OF HALF THE HEIGHT OF THE FENCE. THE SILT SHALL BE REPOSED OF AT AN APPROVED SITE AND IN SUCH A MANNER AS TO NOT CONTRIBUTE TO ADDITIONAL EROSION.

SILT FENCE EROSION CONTROL DETAILS

WATTLE SPACING	
SLOPE	MAXIMUM SPACING
1:1	20'
2:1	30'
3:1	40'
4:1	50'

INSTALLATION NOTES:  
 1. WATTLES SHALL CONSIST OF STRAW, COMPOST, EXCELLESION, OR COCONUT FIBER.  
 2. NOT FOR USE IN CONCENTRATED FLOW AREAS.  
 3. THE WATTLES SHALL BE REMOVED INTO THE CHANNEL A MINIMUM OF TWO (2) INCHES.  
 4. WATTLES SHALL BE INSTALLED PER MANUFACTURER'S SPECIFICATIONS.  
 5. WATTLES SHALL BE INSTALLED PER MANUFACTURER'S SPECIFICATIONS.  
 6. WATTLES SHALL BE INSTALLED ON CENTER WITH A SLIGHT UPWARD CURVE AT THE END OF THE ROW IN ORDER TO OVERLAP JOINTS.  
 7. WATTLES SHALL BE INSTALLED ON CENTER WITH A SLIGHT UPWARD CURVE AT THE END OF THE ROW IN ORDER TO OVERLAP JOINTS.  
 8. WATTLES SHALL BE INSTALLED ON CENTER WITH A SLIGHT UPWARD CURVE AT THE END OF THE ROW IN ORDER TO OVERLAP JOINTS.  
 9. STAKE SPACING SHALL BE 12 INCHES THROUGH THE MIDDLE OF THE WATTLE, LEAVING 2 INCHES OF THE STAKE PROTRUDING ABOVE THE WATTLE WHEN INSTALLING WATTLES ON SLOPES. DRIVE THE STAKES PERPENDICULAR TO THE SLOPE.  
 10. DRIVE THE FIRST END STAKE OF THE SECOND WATTLE AT AN ANGLE TOWARD THE FIRST WATTLE IN ORDER TO HELP ABUT THEM TIGHTLY TOGETHER.  
 11. STAKES SHALL BE REMOVED USING WOOD STAKES TO REMOVE THE WATTLES UP TO 20% SEVERAL INCHES ABOVE THE WATTLE.  
 12. THE CONTRACTOR SHALL REMOVE ACCUMULATED SEDIMENT EVERY TWO WEEKS AND AFTER ANY SIGNIFICANT STORM EVENT AND WHEN SEDIMENT OR FLOW SEDIMENT ACCUMULATED BEHIND WATTLE AS NECESSARY.  
 13. SEDIMENT ACCUMULATED BEHIND WATTLE SHALL BE REMOVED WHEN THE SEDIMENT HAS ACCUMULATED TO THE HALF THE HEIGHT OF THE WATTLE.  
 14. WATTLES SHALL REMAIN IN PLACE UNTIL THE UPSTREAM DISTURBED AREA IS STABILIZED AND IS ACCEPTED.

WATTLE EROSION CONTROL DETAILS

Revs:	Date:

**CONSULTANT**  
 Hodges Engineering  
  
**CIVIL ENGINEER**  
 HODGES ENGINEERING  
 15364 TWIN PINES ROAD  
 LOWELL, AR 72745  
 (479) 713-0341

**BEAVER WATERSHED ALLIANCE**

STATE OF ARKANSAS  
**LICENSED PROFESSIONAL ENGINEER**  
 No. 8289  
 KEVIN E. HODGES

CERTIFICATE OF AUTHORIZATION  
 HODGES ENGINEERING  
 No. 3352  
 ARKANSAS

Drawing Title  
**Stormwater BMP's**

Phase  
**PERMEABLE PAVEMENT & BIOSWALE DESIGN**

Project Title  
**MIRACLE AVENUE LOW IMPACT DEVELOPMENT PLAN**

Location  
**FAYETTEVILLE, ARKANSAS**

Issue Date  
 2024.08.01

Checked  
 KEH

Drawn  
 KEH

Project Number  
 2024-07

Drawing Number  
**C107**